

## Instruction Manual for portable measurement system PCO incl. accompanying Sensors

(Original Instruction Manual – German)



Valid as of Firmware 3.03

NIVUS GmbH  
Im Taele 2  
75031 Eppingen, Germany  
Phone +49 (0)72 62 - 91 91 - 0  
Fax +49 (0)72 62 - 91 91 - 999  
E-mail: [info@nivus.com](mailto:info@nivus.com)  
Internet: [www.nivus.com](http://www.nivus.com)

**NIVUS AG**

Hauptstrasse 49  
CH - 8750 Glarus  
Tel.: +41 (0)55 6452066  
Fax: +41 (0)55 6452014  
E-Mail: swiss@nivus.com  
Internet: www.nivus.de

**NIVUS Sp. z o.o.**

ul. Hutnicza 3 / B-18  
PL - 81-212 Gdynia  
Tel.: +48 (0) 58 7602015  
Fax: +48 (0) 58 7602014  
E-Mail: poland@nivus.com  
Internet: www.nivus.pl

**NIVUS Austria**

Mühlbergstraße 33B  
A-3382 Loosdorf  
Tel.: +43 (2754) 567 63 21  
Fax: +43 (2754) 567 63 20  
E-Mail: austria@nivus.com  
Internet: www.nivus.de

**NIVUS Middle East (FZE)**

Building Q 1-1 ap. 055  
P.O. Box: 9217  
Sharjah Airport International  
Free Zone  
Tel.: +971 6 55 78 224  
Fax: +971 6 55 78 225  
E-Mail: Middle-East@nivus.com  
Internet: www.nivus.com

**NIVUS France**

14, rue de la Paix  
F - 67770 Sessenheim  
Tel.: +33 (0)3 88071696  
Fax: +33 (0)3 88071697  
E-Mail: france@nivus.com  
Internet: www.nivus.com

**NIVUS Korea Co. Ltd.**

#411 EZEN Techno Zone,  
1L EB Yangchon Industrial Complex,  
Gimpo-Si  
Gyeonggi-Do 415-843,  
Tel. +82 31 999 5920  
Fax. +82 31 999 5923  
E-Mail: korea@nivus.com  
Internet: www.nivus.com

**NIVUS Ltd.**

Wedgewood Rugby Road  
Weston under Wetherley  
Royal Leamington Spa  
CV33 9BW, Warwickshire  
Tel.: +44 (0)1926 632470  
E-Mail: info@nivus.com  
Internet: www.nivus.com

**NIVUS Ltd.**

1 Arisaig Close  
Eaglescliffe  
Stockton on Tees  
Cleveland, TS16 9EY  
Phone: +44 (0)1642 659294  
E-Mail: info@nivus.com  
Internet: www.nivus.com

### **Translation**

If the device is sold to a country in the European Economic Area (EEA) this instruction handbook must be translated into the language of the country in which the device is to be used.

Should the translated text be unclear, the original instruction handbook (German) must be consulted or the manufacturer contacted for clarification.

### **Copyright**

No part of this publication may be reproduced, transmitted, sold or disclosed without prior permission. Damages will be claimed for violations. All rights reserved.

### **Names**

The use of general descriptive names, trade names, trademarks and the like in this handbook does not entitle the reader to assume they may be used freely by everyone. They are often protected registered trademarks even if not marked as such.

# 1 Contents

## 1.1 Table of Contents

<b>1</b>	<b>Contents .....</b>	<b>4</b>
1.1	Table of Contents .....	4
<b>2</b>	<b>General .....</b>	<b>6</b>
<b>3</b>	<b>General Notes on Safety and Danger.....</b>	<b>7</b>
3.1	General Danger Signs.....	7
3.2	Special Danger Notes .....	7
3.3	Device Identification .....	8
3.4	Turn-off Procedure .....	9
<b>4</b>	<b>Overview and use in accordance with the requirements</b>	<b>10</b>
4.1	Overview .....	10
4.2	Use in accordance with the requirements .....	11
4.3	Specifications .....	12
4.3.1	Transmitter PCO .....	12
4.3.2	Clamp On System / Sensors.....	12
4.4	Installation of Spare Parts and Parts subject to wear and tear ...	13
4.5	User's Responsibilities .....	13
<b>5</b>	<b>Functional Principle .....</b>	<b>14</b>
5.1	General.....	14
5.2	Flow velocity detection .....	15
5.3	Flow Calculation .....	16
5.4	Device versions .....	17
<b>6</b>	<b>Storing, Delivery and Transport .....</b>	<b>18</b>
6.1	Receipt .....	18
6.2	Delivery .....	18
6.3	Storing .....	18
6.4	Transport.....	19
6.5	Return.....	19
<b>7</b>	<b>Installation.....</b>	<b>20</b>
7.1	General.....	20
7.2	Transmitter Installation and Connection.....	20
7.2.1	Dimensions.....	21
7.3	Sensor installation and connection .....	22
7.3.1	Connection sockets on PCO .....	22
7.3.2	Sensor installation .....	22
7.3.3	Choosing Sensor Position and Calming Sections.....	26
7.3.4	Sensor connection.....	28
7.4	PCO Power Supply .....	29
7.4.1	Battery charging .....	29
<b>8</b>	<b>Initial start-up .....</b>	<b>31</b>
8.1	Notes to the user .....	31
8.2	General Principles .....	31
8.3	Operator Panel .....	32

8.4	Display.....	33
8.5	Operation Basics.....	34
<b>9</b>	<b>Parameter Setting.....</b>	<b>35</b>
9.1	Brief parameter setting (Quick Start).....	35
9.2	Parameter Setting Basics.....	36
9.3	Parameter Tree and Functions.....	36
<b>10</b>	<b>Data evaluation.....</b>	<b>47</b>
10.1	Data handling possibilities.....	47
<b>11</b>	<b>Error description.....</b>	<b>47</b>
<b>12</b>	<b>Analog Inputs and Outputs.....</b>	<b>49</b>
12.1	Analog output Current 0/4 – 20 mA.....	51
12.2	Analog output Voltage 0 – 10 V.....	51
12.3	Analog inputs Power 0/4 – 20 mA.....	51
<b>13</b>	<b>Maintenance and Cleaning.....</b>	<b>52</b>
13.1	Accessories (optional).....	52
<b>14</b>	<b>Emergency.....</b>	<b>53</b>
<b>15</b>	<b>Dismantling/Disposal.....</b>	<b>53</b>
<b>16</b>	<b>Table of Pictures.....</b>	<b>53</b>
<b>17</b>	<b>Index.....</b>	<b>54</b>
<b>18</b>	<b>Declaration of Conformity.....</b>	<b>55</b>

## 2 General



---

***Important***

*READ CAREFULLY BEFORE USE*

*KEEP IN A SAFE PLACE FOR LATER REFERENCE*

---

This Instruction manual for the PCO is intended for the initial start-up of the unit depicted on the title page.

Read the instructions carefully prior to use.

This Instruction manual is part of the PCO delivery and shall be available to users at any time. The safety instructions contained therein must be followed. In case of selling the PCO this technical description must be provided to the purchaser.

The operation of the complete system is described in the separate manual >Technical Instruction for Transit Time Sensors< and >Installation Instruction for Transit Time Sensors<

### 3 General Notes on Safety and Danger

#### 3.1 General Danger Signs



---

**Cautions**

are framed and labelled with a warning triangle.

*This indicates an immediate high risk threatening life and limb.*

---



---

**Danger by electric voltage**

is framed and labelled with the Symbol on the left.

---



---

**Warnings**

are framed and labelled with a "STOP"-sign.

*This indicates a possible risk to persons as well as possible damage to facilities and material.*

---



---

**Notes**

are framed and labelled with a "hand"

---

For connection, initial start-up and operation of the PCO the following information and higher legal regulations (e.g. in Germany VDE), such as Ex-regulations as well as safety requirements and regulations in order to avoid accidents, must be kept.

All operations, which go beyond steps to install, to connect or to program the device, must be carried out by NIVUS staff only due to reasons of safety and guarantee.

#### 3.2 Special Danger Notes

WARNING



---

**Germ contamination**

*Please note that due to the operation in the waste water field the measurement system and cables may be loaded with dangerous disease germs. Respective precautionary measures must be taken to avoid damage to one's health.*

---

### 3.3 Device Identification

The instructions in this manual are valid only for the type of device indicated on the title page.

The nameplate is fixed on the bottom of the device and contains the following:

- Name and address of manufacturer
- CE label
- Type and serial number
- Year of manufacture

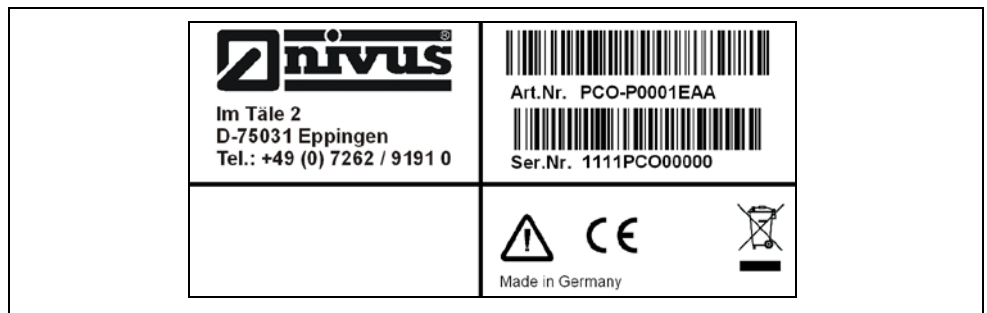

**Fig. 3-1 PCO nameplate**

- The nameplate can be found on the reverse side of the transmitter specifying series and type as well as the serial no.
- Year of manufacture

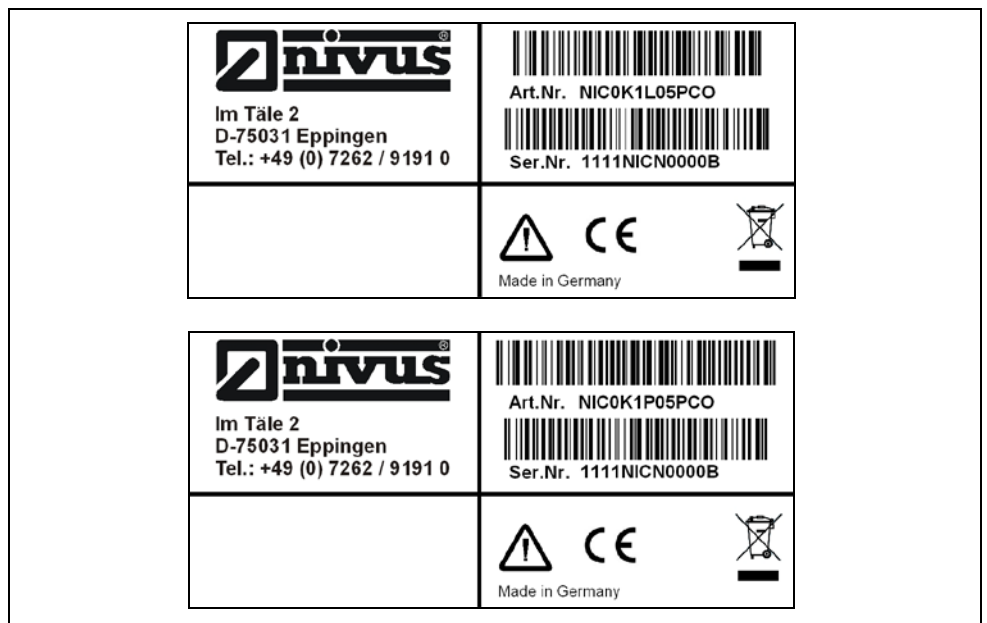

**Fig. 3-2 Nameplate flow velocity sensor, type NIC0**



Additionally each sensor is equipped with a protected nameplate protected by a transparent shrunk-on hose at both ends of the fixed cable. It contains the following:

- Type key of the sensor
- Serial number of the sensor

It is important for enquiries and replacement part orders to specify article number as well as serial number of the respective transmitter or sensor. This ensures correct and quick processing.



---

*This instruction manual is a part of the device and must be available for the user at any time.*

---

*The safety instructions contained within must be followed.*

---

**WARNING**



---

***Do not disable safety devices!***

*It is strictly prohibited to disable the safety devices or to change the way they work.*

---

### 3.4 Turn-off Procedure



---

*For maintenance, cleaning and repairs (authorized staff personnel only) the device has to be disconnected from battery.*

---

## 4 Overview and use in accordance with the requirements

### 4.1 Overview

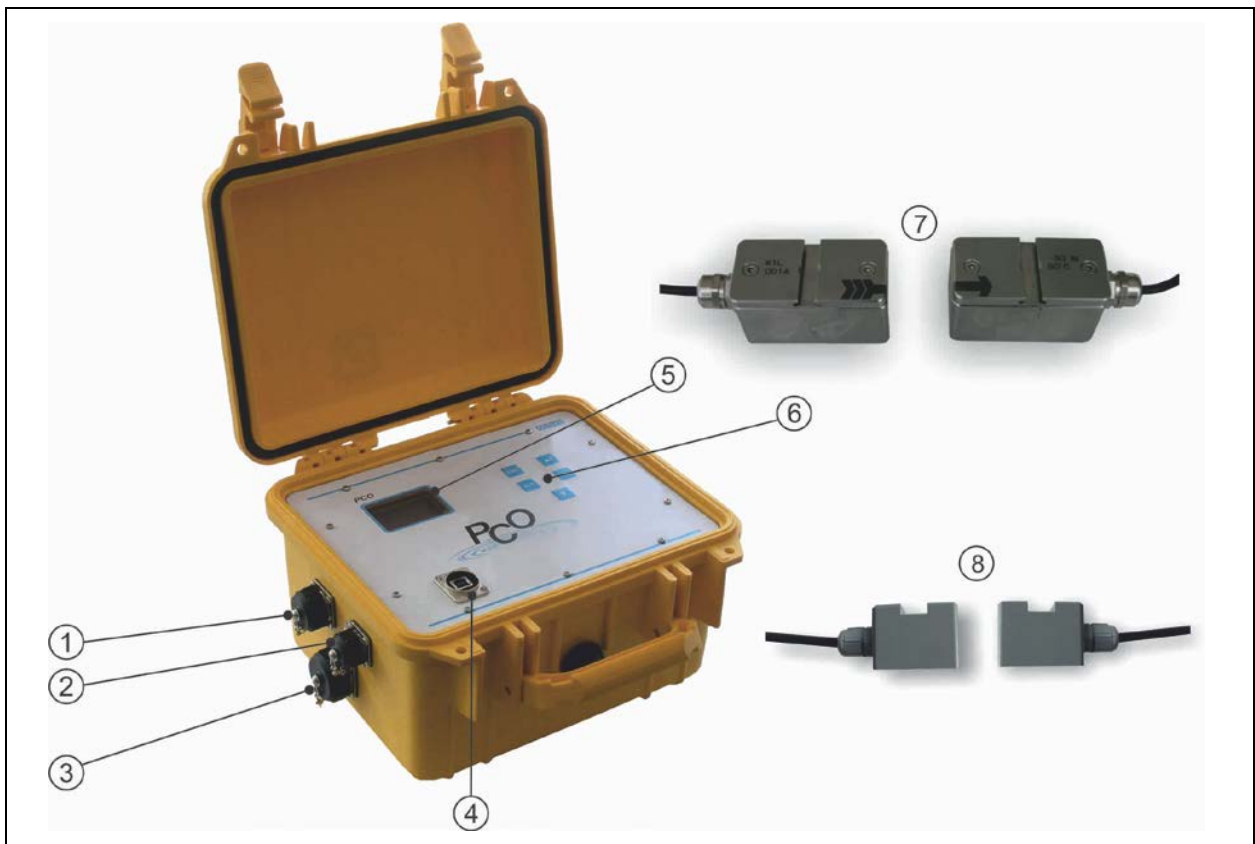

- 1 Socket for connection of sensors
- 2 Charger socket for rechargeable battery
- 3 Socket for communication
- 4 USB interface
- 5 Display
- 6 Keypad
- 7 Clamp-on sensor pair made of stainless steel/PEEK
- 8 Clamp-on sensor pair made of plastic

**Fig. 4-1 Overview PCO and sensors**

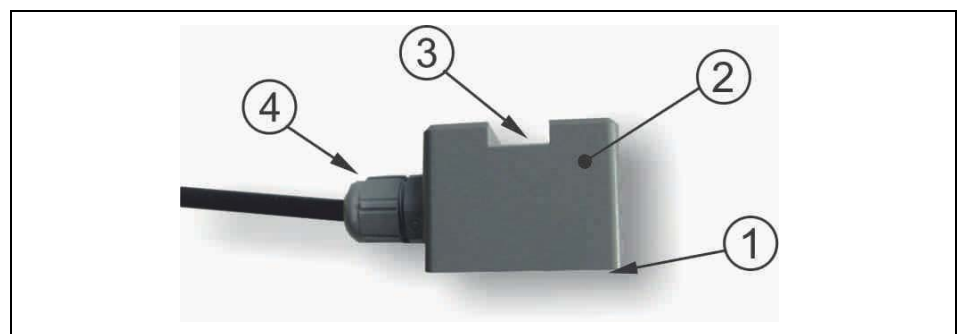

- 1 Sensor surface
- 2 Sensor body made of plastic
- 3 Groove slot for tensioning belt fastening
- 4 Cable gland

**Fig. 4-2 Overview Clamp-on sensor**

## 4.2 Use in accordance with the requirements

### WARNING



#### **Damage due to improper use**

*The device is exclusively intended to be used for purposes as described above.*

*Modifying or using the devices for other purposes without the written consent of the manufacturer will not be considered as use in accordance with the requirements.*

*Damages resulting from this are left at user's risk.*

*The device is designed for a lifetime of approx. 10 years. After that period an inspection in addition with a general overhaul has to be made.*

---

The measurement device type PCO including respective sensors is intended to be used for continuous flow measurement in slightly polluted to clear, clean water or homogeneous media on full pipes. Here the allowed maximum values and pipe materials, as specified in chapter 4.3 must be strictly kept. All cases which vary from these conditions and are not passed by NIVUS GmbH in writing are left at owner's risk.



#### **Note**

*For installation and initial start-up the conformity certificates and test certificates of the respective authorities as well as applicable national regulations shall be followed.*



#### **Important Note**

*The transmitter and the sensors always have to be installed outside of Ex-zones!*

### 4.3 Specifications

#### 4.3.1 Transmitter PCO

Power Supply	Internal batteries NiMH 6 VDC, 20Ah or additional external rechargeable battery pack
Power consumption	< 5 VA
Enclosure	<ul style="list-style-type: none"> <li>- Material: Polypropylene</li> <li>- Weight: ca. 750 g without battery</li> <li>- Protection: IP 67 if lid is closed and locked</li> </ul>
Operating Temperature	-10 °C to +60 °C
Storage Temperature	0 °C to +70 °C
max. Air Humidity	80 %, non-condensing
Display	backlit graphic display, 128 x 64 pixel
Operation	5 keys, conversation mode in German, English, French (other languages upon request)
Inputs / Outputs	<ul style="list-style-type: none"> <li>- 4 slots, each of them for:</li> <li>1x analog input passive 0/4 – 20, U=30 VDC, Ri=50 Ohm or</li> <li>1x analog input active 0/4 – 20 or</li> <li>1x analog output 0/4 – 20 mA or</li> <li>1x analog output 0 – 10 VDC</li> </ul>
Data storage	internal data storage for up to 32 MB Flash
Data transmission	Serial interface RS232, RS485, ModBus RTU (all via USB interface) or optional external GPRS- Modem (Type NivuLog Easy)

#### 4.3.2 Clamp On System / Sensors

Measurement principle	Ultrasonic transit time as clamp-on system
Material	PEEK and stainless steel 1.4571
Measurement frequency	1 MHz; other frequencies upon request
Flow velocity range	±20 m/s
Inner pipe diameter:	0.08 m to 1,4 m (DN 80 to DN 1400)
Protection	IP 68
Operating temperature	-30 °C to +80 °C (environment)
Storage temperature	0 °C to +80 °C
Cable length	5 m
Cable type	Twinax
Outside cable diameter	5 mm
Sensor types	Clamp-on sensor pair for clamp-on installation on pipes
Measurement uncertainty depending on hydraulic conditions	<ul style="list-style-type: none"> <li>- Flow velocity (<math>v_{average}</math>) in path ±0,1 % of measurement value</li> <li>- repeatability 0.15 % of measurement value ± 5 mm/s</li> <li>- Flow rate (Q): ±1-5 % of measurement value to 0.5 % after the measurement place has been calibrated</li> <li>- offset velocity &lt; ±5 mm/s</li> </ul>

Temperature measurement via sound velocity	
Measurement range in medium	0 °C to +80 °C
Measurement uncertainty	± 1 K

#### 4.4 Installation of Spare Parts and Parts subject to wear and tear

We herewith particularly emphasize that replacement parts or accessories, which are not supplied by us, are not certified by us, too. Hence, the installation and/or the use of such products may possibly be detrimental to the device's ability to work.

Damages caused by using non-original parts and non-original accessories are left at user's risk (Accessories see chapter 13.1)

#### 4.5 User's Responsibilities



---

*In the EEA (European Economic Area) national implementation of the framework directive 89/391/EEC and corresponding individual directives, in particular the directive 89/655/EEC concerning the minimum safety and health requirements for the use of work equipment by workers at work, as amended, are to be observed and adhered to.*

*In Germany the Industrial Safety Ordinance must be observed.*

---

The customer must (where necessary) obtain any local **operating permits** required and observe the provisions contained therein.

In addition to this, he must observe local laws and regulations on

- personnel safety (accident prevention regulations)
- safety of work materials and tools (safety equipment and maintenance)
- disposal of products (laws on wastes)
- disposal of materials (laws on wastes)
- cleaning (cleansing agents and disposal)
- environmental protection

All approvals from respective authorities shall be followed according to the latest applicable version.

##### **Connections**

Before operating the device the user has to ensure, that the local regulations (e.g. for operation in channels) on installation and initial start-up are taken into account, if this is both carried out by the user.

## 5 Functional Principle

### 5.1 General

PCO is a non-contact, portable measurement system for flow measurement and hence is pressure-independent. It is mainly designed for use in slightly polluted to clear watery fluids of various consistencies. It can exclusively be operated in full filled channels and pipes.



*The flow velocity measurement method is based on the ultrasonic transit time principle. Due to this reason it is indispensable for the system functionality that the solid content (dirt particles, gas bubbles or similar) is not too high to enable ultrasonic signal transmission between both sensors due to reflections and hence damping.*

The PCO uses up to two sensor pairs for flow velocity determination.

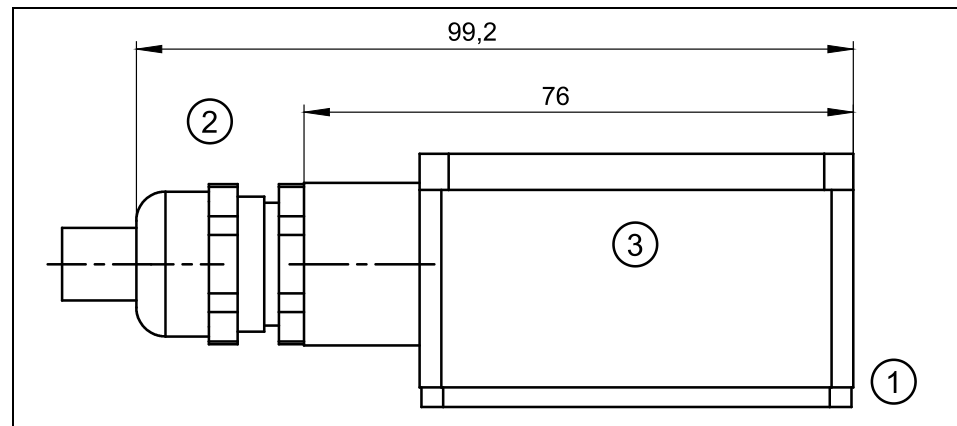

- 1 sensor face
- 2 cable gland
- 3 sensor housing, material stainless steel 1.4571

**Fig. 5-1 Assembly of clamp on sensors incl. strap**

## 5.2 Flow velocity detection

The flow velocity is determined by using the ultrasonic transit time principle.

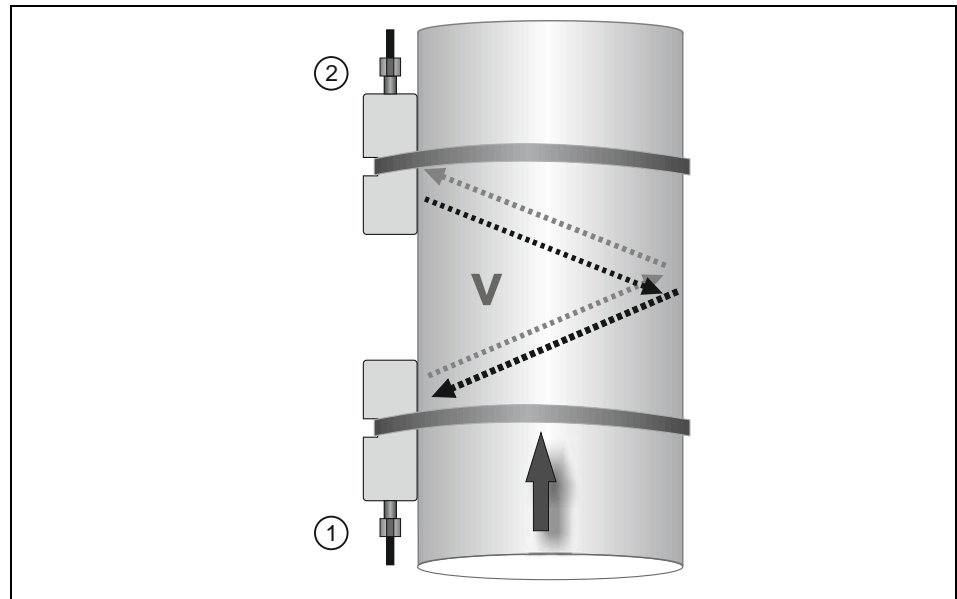

- 1 Sensor 1
- 2 Sensor 2

**Fig. 5-2 One-path transit time measurement principle**

This measurement principle is based on directly measuring the transit time of acoustic signals between two ultrasonic sensors.

A short ultrasonic impulse with a defined frequency sent towards the medium flow direction in a defined angle requires a longer transit time than another impulse being sent with the medium flow direction in an inverse angle.

The difference between the transit times is proportional to the average flow velocity within the measurement path.

Flow determination is possible as soon as both cross-sectional areas as well as flow geometry of pipe or channel are known.

Presuming that  $C \gg v_{1-2}$  and the flow direction is known, it is possible to approach the transit time ( $\Delta t$ ) applying

$$\Delta t = \frac{2L_{1-2} \cdot v_{1-2}}{c^2}$$

Whereat:

$L_{1-2}$  length of acoustic measurement path between sensors 1 and 2

$C$  velocity of sound in water

$v_{1-2}$  average flow velocity between sensors 1 and 2 along the measurement path

### 5.3 Flow Calculation

In case of using single-path or two-path installations in one level under the condition

$$Q = v_m \cdot A$$

Given:

$v_m$  average flow velocity

A cross-sectional flow area

it is required to involve a velocity coefficient  $k$  in order to compensate the difference between measured velocity  $v_g$  and average velocity  $v_m$  within the cross-sectional area.

$$k = \frac{v_m}{v_g}$$

Using the transit time of the signal it is possible to calculate flow subsequently as described below:

$$Q = k \cdot A \cdot v_g = k \cdot A \cdot \frac{L_{1-2}}{2 \cdot \cos \Phi_{1-2}} \cdot \left( \frac{1}{t_{1-2}} - \frac{1}{t_{2-1}} \right)$$



## 5.4 Device versions

PCO transmitter and the respective flow velocity sensors are available in different versions. The tables below provide an overview on various possibilities.

### Transmitters

The transmitters mainly vary in terms of different I/O versions. The current type of device is indicated by the article number, which can be found on a weather-proof label on the rear side of the enclosure.

From this article key the type of device can be specified.

<b>PCO-</b>	Portable Flow Measurement Transmitter		
	<b>Construction</b>		
	<b>P000</b>	Plastic housing , IP67 with plug connection for Clamp-on sensors	
		<b>Analog Outputs</b>	
	<b>000</b>	none	
	<b>1AA</b>	1 Output 0/4 - 20 mA	
	<b>1AV</b>	1 Output 0 - 10 V	
	<b>2AA</b>	2 Outputs 0/4 - 20 mA	
	<b>2AV</b>	2 Outputs 0 - 10 V	
		<b>Analog Inputs</b>	
	<b>0000</b>	none	
	<b>1EAA</b>	1 Input 0/4 - 20 mA; active, for 2-wire power supply 30 V DC (max. 48 mA)	
	<b>1EAP</b>	1 Input 0/4 - 20 mA; passive	
	<b>2EAA</b>	2 Inputs 0/4 - 20 mA; active, 2-wire power supply 30 V DC (max. 48 mA)	
	<b>2EAP</b>	2 Inputs 0/4 - 20 mA; passive	
<b>PCO-</b>	<b>P</b>		

Fig. 5-3 Type keys for PCO transmitters

### Ultrasonic sensors for PCO

The sensors are available in two various constructions.

The article no. can be found on a nameplate on the cable end (device side) which is protected by a transparent shrunk-on hose

<i>NIC0K1P05PCO</i>	1 Sensor pair, material PVC, operating temperature -20 °C to +50 °C
---------------------	---

Fig. 5-4 Type keys for clamp on sensors NIM0K1P

<i>NIC0K1L05PCO</i>	1 Sensor pair, material stainless steel / PEEK, operating temperature -30 °C to +80 °C
---------------------	--

Fig. 5-5 Type keys for clamp on sensors NIM0K1L

## 6 Storing, Delivery and Transport

### 6.1 Receipt

Please check your delivery according to the delivery note for completeness and intactness immediately after receipt. Any damage in transit must be instantly reported to the carrier. An immediate, written report must be sent to NIVUS GmbH Eppingen as well.

Please report any delivery incompleteness in writing to your representative or directly to NIVUS Eppingen within two weeks.



---

*Mistakes cannot be rectified later!*

---

### 6.2 Delivery

The standard delivery of the PCO measurement system contains:

- The instruction manual with the certificate of conformity. Here, all necessary steps to correctly install and to operate the measurement system are listed.
- a PCO transmitter
- min. two ultrasonic sensors, construction: clamp on

Additional accessories such as rechargeable, battery, battery charger, connection cable or similar depending on order. Please check by using the delivery note.

### 6.3 Storing

The following storing conditions shall be strictly observed:

Transmitter:	max. temperature:	+ 70°C
	min. temperature:	0°C
	max. humidity:	80 %, non-condensing
Sensor:	max. temperature:	+ 70°C
	min. temperature:	- 30°C
	max. humidity:	100 %

The devices must be protected from corrosive or organic solvent vapours, radioactive radiation as well as strong electromagnetic radiation.

## 6.4 Transport

### WARNING



---

*Use the unit handle to carry the PCO in the measurement place area! Carrying, lifting or lowering the device on the sensor cable is not allowed!*

---

Sensors and Transmitter are conceived for harsh industrial conditions. Despite this do not expose them to heavy shocks or vibrations.  
Transportation must be carried out in the original packaging.

## 6.5 Return

The units must be returned at customer cost to NIVUS Eppingen in the original packaging.  
Otherwise the return cannot be accepted!

## 7 Installation

### 7.1 General

Before feeding the rated voltage to transmitter and sensor the installation must be correctly completed and verified. The installation should be carried out by qualified personnel only.

The installation of the sensors is described in the separately „Installation Instruction for Transit Time Sensors“, which is a part of the sensor delivery.



---

*For use in accordance with the requirements – flow detection – and the further use of the gained data it is necessary to have comprehensive knowledge about hydraulic conditions. Please note that improper, faulty or unsuitable installation as well as selecting unsuitable or hydraulically problematic measurement places may lead to faulty or incomplete measurement values which may be insufficient for further processing and editing. This is why the installation should be carried out by authorized personnel only.*

---

If required, NIVUS can organise any training on hydraulics / device specs. Further statutory standards, regulations and technical rulings have to be taken into account.

### 7.2 Transmitter Installation and Connection

#### WARNING



---

#### ***Risk of cable break or tear-off***

*The PCO shall be suspended into shafts or manholes only by using the carrying handle and sufficient straps, ropes or similar.*

*It is not allowed to suspend the unit by using the sensor cable as this may lead to cable breaks, leaky plug connections or the transmitter may be torn off and even get lost.*

---

Bitte beachten Sie bei den Montagearbeiten, dass Elektronikbauteile durch elektrostatische Entladungen zerstört werden können. Daher ist bei der Installation darauf zu achten, dass durch geeignete Erdungsmaßnahmen unzulässig hohe elektrostatische Aufladungen vermieden werden.

### General

The transmitters mounting place has to be selected according to certain criteria. Please strictly avoid:

- direct sunlight (use weatherproof cover if necessary)
- heat emitting objects (max. ambient temperature: +40°C (104°F))
- objects with strong electromagnetic fields (e.g. frequency converters)
- corrosive chemicals or gas
- mechanical shocks
- installation close to footpaths or travel ways
- vibrations
- radioactive radiation



*Before locking the enclosure lid please make sure that the sealing is not damaged and clean. Debris and/or dirt shall be removed and the gasket shall be greased again with silicone if required. Damages resulting from leakage or defect sealing are not covered by the manufacturer's liability.*



### Important Note

*Sockets on the PCO which are not required for measurements, sensors or data transmission must be locked watertight before installation by using the covers fastened on each socket. Otherwise the protection grade of the entire unit is no longer guaranteed. Damages resulting from the non-use of the covers are not covered by the manufacturer's liability.*

*Covers damaged due to the use of force can be ordered from NIVUS at extra costs.*

### 7.2.1 Dimensions

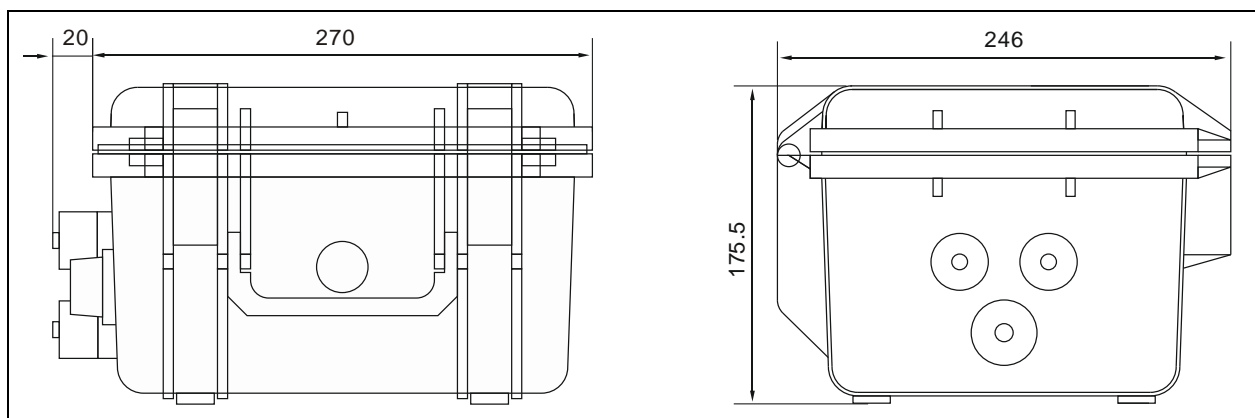
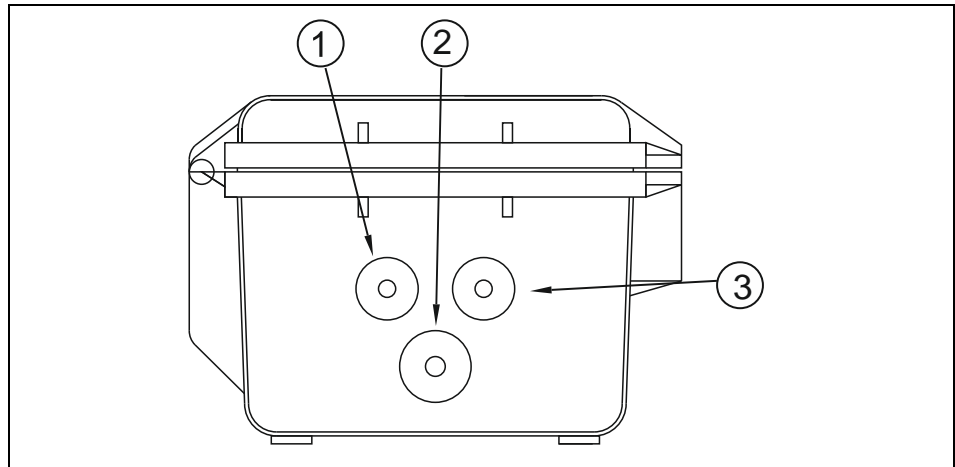

Fig. 7-1 PCO Enclosure

### 7.3 Sensor installation and connection

#### 7.3.1 Connection sockets on PCO



- 1 Socket for sensor pair
- 2 Multifunctional socket
- 3 Charging socket

**Fig. 7-2 PCO Enclosure and connection sockets**

#### 7.3.2 Sensor installation

**WARNING**



*The minimum bending radius of the standard signal cable is 10 cm (3.94 in). Smaller radii may result in cable break.*

For installation of the sensors used please also read the >Installation Instruction for Transit Time Sensors< which is part of the sensor delivery.

The sensors shall be installed by using NIVUS mounting accessories (see chapter 13.1). Before installing the sensor, please check material, quality structure and wall thickness of the pipe. The material should be cast steel, steel or stainless steel. These materials can be selected directly from the start-up menu.



*Before mounting the sensors, the transmitter must be programmed (see chapter 9).*

Subsequently install the first sensor in flow direction according to the respective marking (Arrows).

Apply coupling paste to the surface touching the pipe, thread the clamp band and attach the sensors on the pipe with the arrow pointing in flow direction (according to path arrangement). Please observe to have a sufficient amount of coupling paste being applied to the sensor face.



**Fig. 7-3 Sensor pair (sensor A and B)**

Please use the optional delivered clamp bands or the rail system of NIVUS (mounting accessory) for mounting. First shorten the clamp band to the length required. Then insert the clamp band into the slotted clamp and bend it over. Please observe to have the marked side of the slotted clamp facing upwards.



**Fig. 7-4 Clamp band for clamp on sensors**

Now put on the turnbuckle, fix it by folding over and tighten the knurled screw using an Allen® key.  
Apply coupling paste onto the sensor area touching the pipe. Put the tensioning belt through the slot on the top of the sensor in a way that the arrow on the sensor top is looking in the flow direction (according to path arrangement).

Attach the second sensor parallel to the pipeline. The transmitter indicates the required distance to the previously mounted sensor.  
Install the sensor as described before (sensor 1).

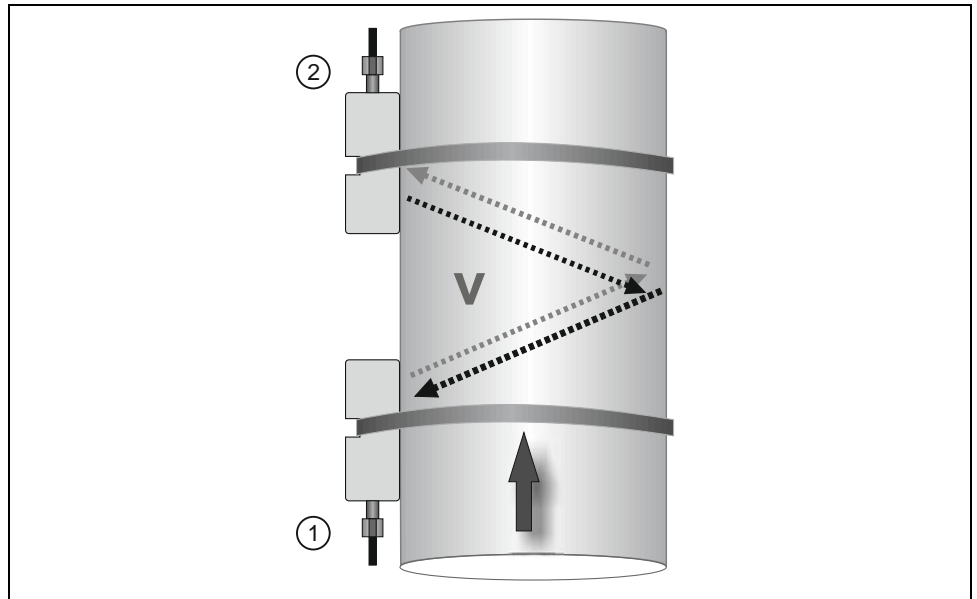

- 1 Sensor 1
- 2 Sensor 2

**Fig. 7-5 1 path measuring, path arrangement: V-monitoring**

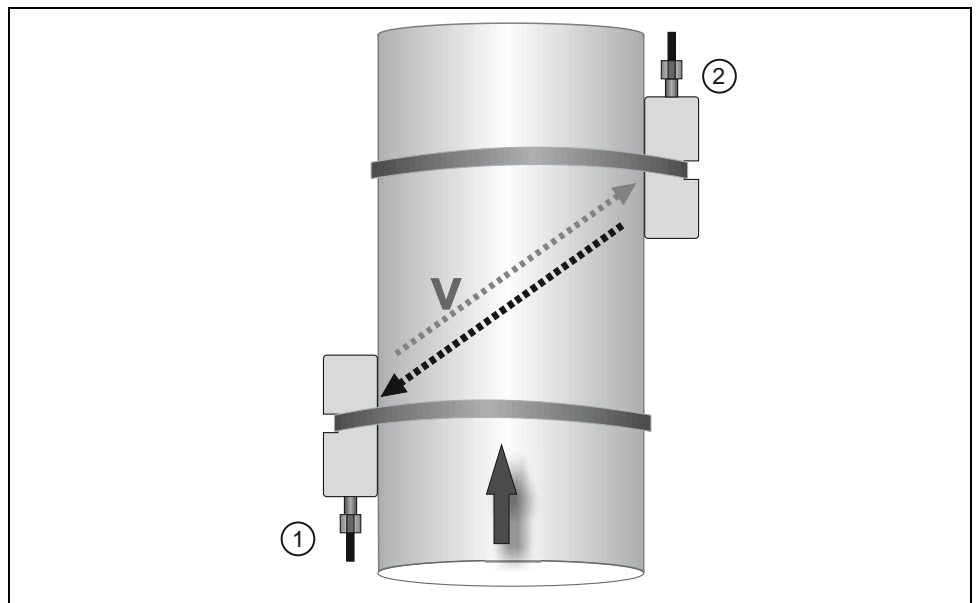

- 1 Sensor 1
- 2 Sensor 2 (on reverse side of the pipe)

**Fig. 7-6 1 path measuring, path arrangement: diagonal**



*To avoid disturbances from electrical interferences, the sensor cable must not be laid close to engine (motor) lines or main power lines.*



A precise sensor alignment is very important for a correct function of the transit time measurement. You can check this right after the start of the measurement (see chapter 9.1). Re-adjust the sensor alignment only at one sensor. After obtaining the highest possible signal strength fasten the sensors by tightening the turnbuckles. Press ,ENTER' on the transmitter and the measurement will start.

In case of horizontally laid pipes avoid pipe top and pipe bottom as mounting place (risk of soiling or air bubbles resulting in measurement failure). NIVUS recommends a mounting position of  $-45^\circ$  ...  $+45^\circ$  to the horizontal.

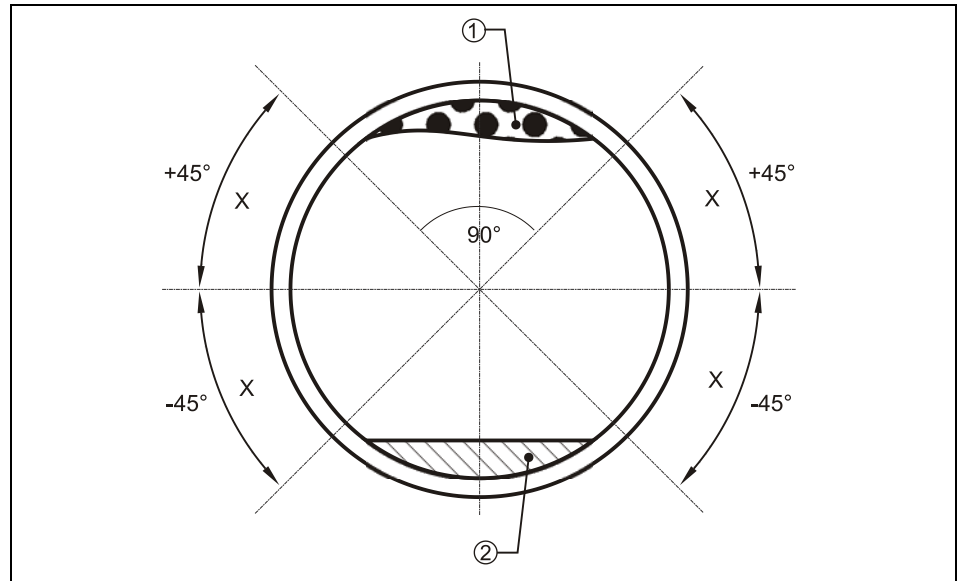

- X = Recommended sensor installation positions
- 1 = Risk of air-bubbles
- 2 = Risk of sludge deposits

**Fig. 7-7 Recommended installation angles**

### 7.3.3 Choosing Sensor Position and Calming Sections

Clear and defined hydraulic conditions are indispensable prerequisites for accurate measurements. This is why one has to be especially attentive to the required hydraulic calming sections.

- The pipe must be full filled
- Strictly avoid falls, steps or obstructions, fittings, profile change of channels or supplies from the side upstream as well as downstream of the measurement point!
- The length of the approach channel must be min. 5x nominal diameter, the length of the discharge channel must be min. 2x nominal diameter. Longer sections may be required however in case of disturbed hydraulic conditions and distorted flow profiles resulting from these conditions.
- Avoid changes of slopes within the measurement section

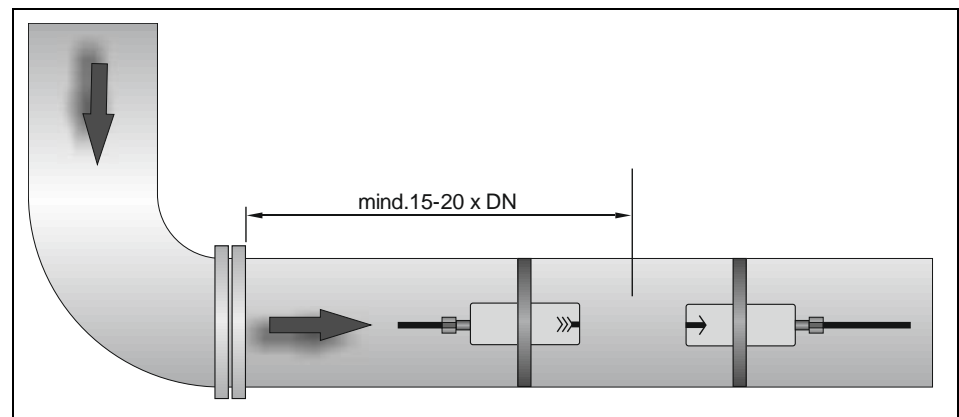

$\alpha \leq 15^\circ$	$L \geq \text{min. } 3x \text{ DN}$	$L \geq \text{min. } 5x \text{ DN}$
$\alpha \leq 45^\circ$	$L \geq \text{min. } 5x \text{ DN}$	$L \geq \text{min. } 10x \text{ DN}$
$\alpha \leq 90^\circ$	$L \geq \text{min. } 10x \text{ DN}$	$L \geq \text{min. } 15-20x \text{ DN}$

**Fig. 7-8 Sensor position behind curves or elbows**

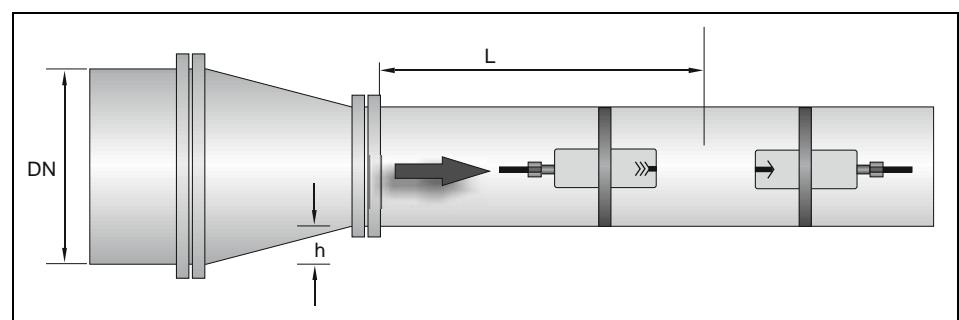

$h \leq 5\%$ of nominal diameter	$L \geq \text{min. } 3x \text{ DN}$
$h > 5\%$ of nominal diameter	$L \geq \text{min. } 5x \text{ DN}$
$h \geq 30\%$ of nominal diameter	$L \geq \text{min. } 10x \text{ DN}$

**Fig. 7-9 Sensor position after change of profile (side view)**

A correct and reliable measurement can be performed only in full filled pipes. For this reason do not install measurements in downpipes or at the highest point of the pipeline.

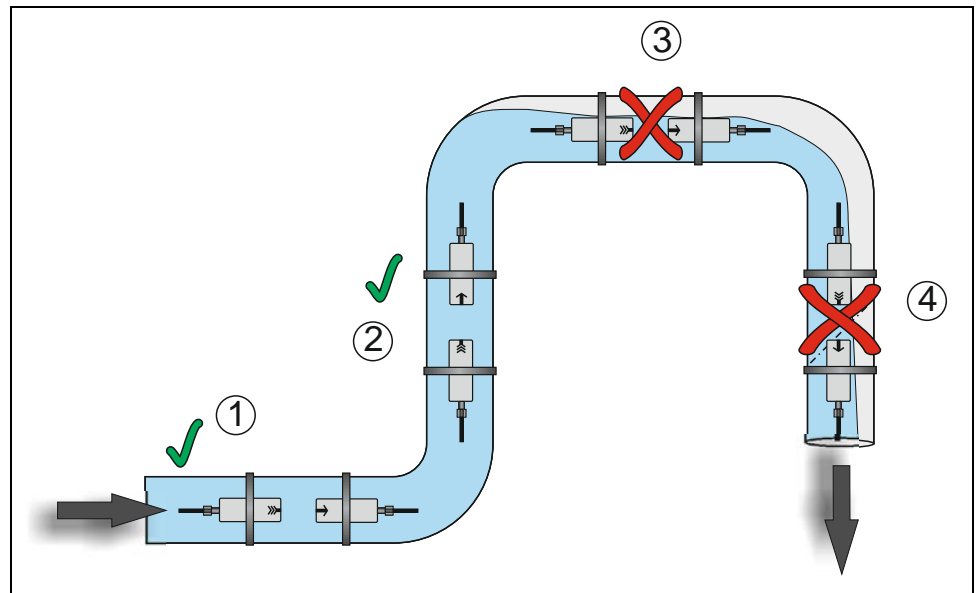

- 1 = recommended range in almost horizontal position (sensor can be installed on the side)
- 2 = recommended range in vertical pipe
- 3 = not recommended due to part filling/idling
- 4 = measuring impossible due to idling

**Fig. 7-10 Comparison of installation places**

In case of planning measurements in horizontal pipelines we recommend to consider a slightly inclined section or an inverted siphon (sensor installation as depicted in Fig. 7-7).

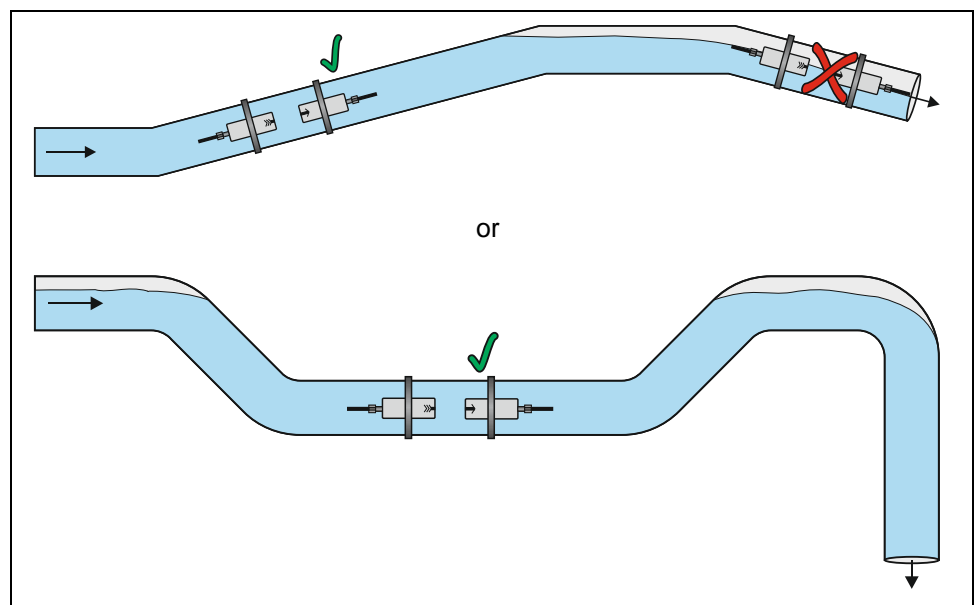

**Fig. 7-11 Horizontal pipe with inverted siphon**

The Sensors shall be installed **always upstream** of shut-off valves and control fittings.

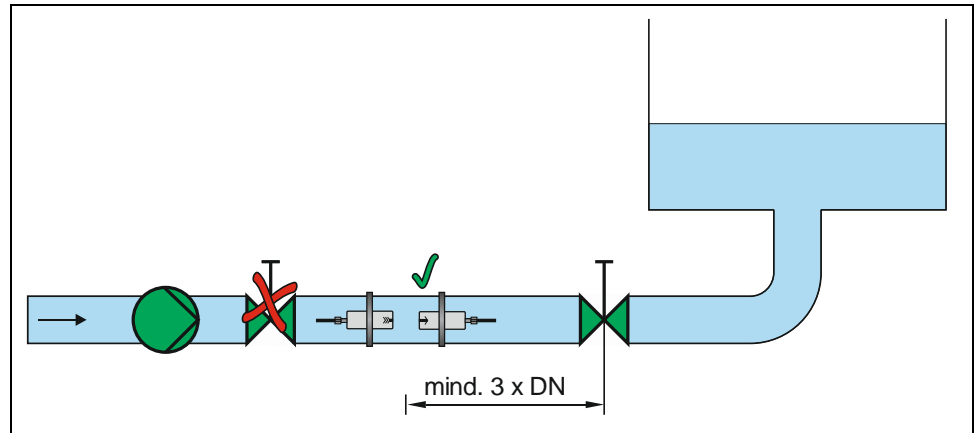

Fig. 7-12 Using shut-off valves and control fittings

#### 7.3.4 Sensor connection

**WARNING**



**Never modify cable lengths**

*Never modify the length of the sensor cables. This may result in errors or even complete failures of the measurement.*



*Common extensions combining different applications or common extensions combining separate signals or flow measurements are not allowed.*



The Sensors are equipped with the respectively wired plugs. The sensor cable must not be extended or shortened. These plugs must be connected to the transmitter according to Fig. 7-2. To do this, unscrew the protective covers from the required sockets, plug in and manually tighten the screw caps on the plugs in order to ensure the grade of protection and secure contact and sensor plug.

*Keep threads of plugs and sockets carefully free of dirt, sand or similar and clean the threads with a soft and lint-free cloth prior to connection if required.*

*Please necessarily lock unused plug connections with the protective caps. Otherwise the unit's protection degree is not maintained!*

## 7.4 PCO Power Supply

### General

The PCO is equipped with a state-of-the-art rechargeable NiMH battery pack. This pre-configured battery pack ensures long lifetime of the measurement as well as safe operation.

The rechargeable battery is firmly installed in the bottom part of the unit. This battery pack may be replaced other modified by authorised personnel or the manufacturer only.



---

*If spare parts or other parts (e.g. batteries or similar) which are not licensed by NIVUS are used, all warranty claims or liability will expire.*

---

### 7.4.1 Battery charging

#### WARNING



---

#### **Use original parts only, risk of destruction**

*Charging the batteries is allowed in non-Ex-areas and in dry environments only.*

*To charge the NiMH battery, use exclusively the accompanying battery charger for NiMH batteries by NIVUS. Please note the specifications of the battery charger.*

*The use of inappropriate battery chargers may lead to battery damage such as battery leakage, explosion etc.*

---

The rechargeable battery normally comes in charged condition. Due to reasons of operational safety the battery must be charged before the first initial start-up however. Therefore connect the PCO with the Battery charger.



---

*The battery should be recharged each time before using the PCO.*

---

To charge batteries in non-Ex areas use the according battery charger (see chapter 13.1).



The unit indicates the charging process showing an appropriate symbol in the top line of the display.



**Fig. 7-13 Connection Battery charger with PCO**

The maximum capacity of the rechargeable NiMH battery is going to deteriorate in the course of time. This will reduce the lifetime which cannot be considered by the integrated lifetime calculation function of the PCO.  
High or low ambient temperatures and long periods of use are going to reduce the battery capacity as well.



---

*Rechargeable batteries are subject to wear and tear and hence shall be checked or replaced if required after a period of 2 years. Intensive use may reduce this period.*

---



---

*Never remove screws from the transmitter or the cover plate containing the display!*

---

## 8 Initial start-up

### 8.1 Notes to the user



---

*To put the entire measurement system into operation it may be possible to additionally consult the following manuals:*

*> Technical Instruction of Transit Time Sensors <*

*> Installation Instruction for Transit Time Sensors <*

*These documents are part of the standard sensor delivery.*

---

Before you connect and operate the PCO you should strictly follow the notes below!

This instruction manual contains all necessary information to program and to operate the device. It is addressed to qualified technical staffs that have appropriate knowledge about measurement technology, automation technology, information technology and waste water hydraulics.

To ensure a correct function of the PCO this instruction manual must be read thoroughly!

The safety instructions must be duly observed!

If any problems regarding the selection of measurement places, installation, connection or programming should occur please contact our technical division or our service centre.

#### **NIVUS GmbH**

Service-Hotline,  
or via E-Mail:

Tel. +49 (0)7262 9191-955

[Hotline-worldwide@nivus.com](mailto:Hotline-worldwide@nivus.com)

### 8.2 General Principles

The initial start-up is not allowed until the installation is finished and checked. To exclude faulty programming this instruction manual must be read before the initial start-up in order to eliminate the possibility of faulty programming.

Please get used to the PCO programming via display and keyboard by reading the instruction manual before you begin to program the device.

After transmitter and sensors are connected (see chapter 7.2 and 7.3) the parameters must be set. In the most cases all you need is:

- enter the geometry of the measurement place (pipe parameters)
- enter the parameters of the fluid to measure
- A select the sensor type (if not detected automatically)
- set the storage mode / operation mode
- verify and if required correct the system clock (time and date)

The PCO user surface is designed in a way that even unfamiliar users are able to easily set up basic settings in graphic dialog mode which ensure reliable device operation.

For extensive programming, difficult hydraulic conditions, in case of absence of expert staff or if a setup and error protocol is required, the programming should be carried out by the manufacturer or an expert company which is authorised by the manufacturer.

### 8.3 Operator Panel

There is a comfortable 5-button keypad available for data input.

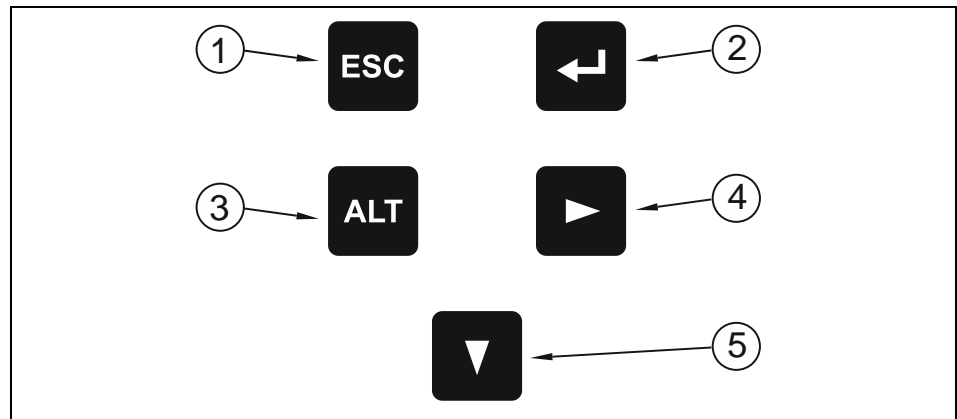

- 1 ESC- key (Escape)
- 2 Confirmation key (ENTER)
- 3 Shift key (ALT)
- 4 Navigation key right (→)
- 5 Navigations / changing key (↓)

**Fig. 8-1** Operator panel



## 8.4 Display

The PCO has a large back-lit graphic display with a resolution of 128 x 64 Pixel. This ensures comfortable communication.

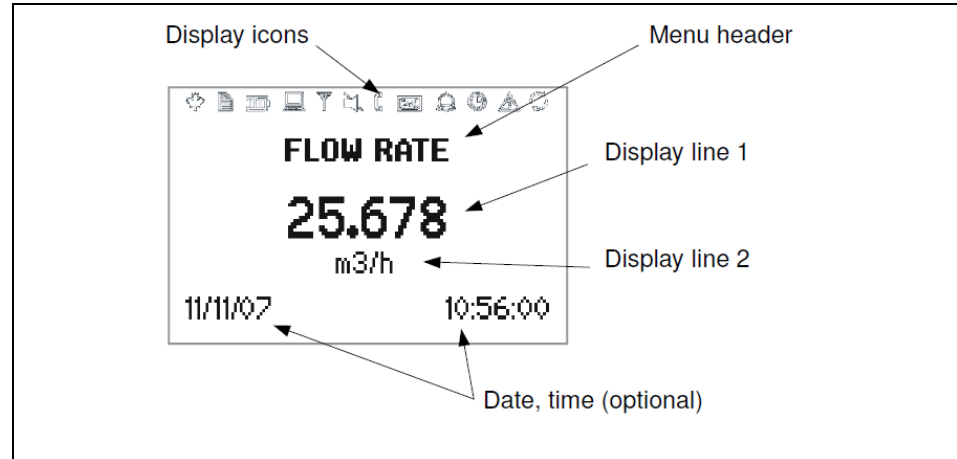

Fig. 8-2 Display

Display	Function	Meaning
	ON OFF	Not used
	ON OFF	Data logger in use Data logger OFF
	ON Blinking	Indicates the charging level. battery is being charged
	ON OFF	Backlight on Backlight off
	ON OFF	Error I/O processor No error I/O processor
	Crossed out Not crossed out	Tones switched on tones not operating
	ON OFF	Poor sensor coupling Sensor coupling OK
	ON OFF	Not used
	ON OFF	Not used
	ON OFF	Date / time set Error clock
	ON OFF	Errors recorded in Error Log no error detected
	ON OFF	Serial communication active Serial communication inactive

Table 1 Display Icons

Two basic menus can be selected, visible in the headline of the display. They can be selected individually. The menus are:

<b>Main menu</b>	This menu serves to enter all parameters required to operate the unit. Moreover it is possible to execute diagnostic functions as well as to set up communication / data storage options.
<b>Quick start menu</b>	This menu allows to easily start up the unit by using a wizard (the wizard will request all parameters required for proper unit operation step by step). Furthermore existing configurations and settings can be saved and loaded here (e.g. to recall settings for measurement places to repeat measurements).
<b>ESC</b>	Toggle between the menus by using the ESC key.

## 8.5 Operation Basics

The entire operation is menu driven and supported by explanatory graphics. To navigate within the menu structure use the 2 control keys (see chapter 8.2).



Use "Arrow down" or "ENTER" to select main menus.



Exit the selected submenu step by step using the "ESC" key. Entries will be rejected without being accepted.



In some menus "ALT" allows to select items (e.g. to select values / data to save). In main menu the backlight can be turned on / off using this key.



Use the "Arrow right" key to increase the display brightness.

## 9 Parameter Setting

### 9.1 Brief parameter setting (Quick Start)

For standard applications such as full pipe and flow velocity measurement by using one sensor pair, it is sufficient to enter a few basic settings with the aid of the setup wizard, as briefly mentioned below.

1. Connect sensor to the measurement transmitter
2. Switch the measurement transmitter on  
(press ENT key for more than 2 seconds)
3. In QUICK START MENU select the setup wizard with ,ENTER' and select the parameters as determined by the following sequence:
  - Select standard values (centre part of display)
  - Select pipe material
  - Enter the outer pipe diameter (modify values with ,Arrow down', next character with ,Arrow right')
  - Enter the pipe wall thickness
  - Select type of liquid being measured
  - Enter the fluid temperature during start-up
  - Enter the parameters (material and thickness) of the inner lining (if available)
  - Enter the number of acoustic paths through the medium (e.g. V-mode measurement = 2 acoustic paths)
4. The measurement now can be activated in menu ,Start measurement'
5. Read the calculated distance between the two sensors on the display
6. Install the sensors with the indicated distance and check alignment by verifying the signal strength as well as the indicated distance.

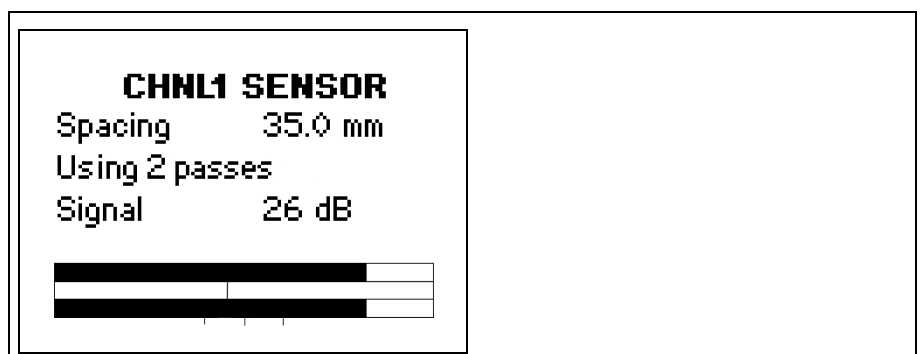

7. Measurement starts after pressing the ,ENTER'- button

#### Additional settings

8. The measurement can be interrupted by pressing ,ESC'

## 9.2 Parameter Setting Basics

Press <ENT> for more than 2 seconds to turn the unit on.  
Measurement is not possible while parameters are set on the unit.  
Press and hold <ESC> again to turn the unit off.

The PCO automatically executes a hardware and software check as soon as it has been turned on.

After the check has been accomplished successfully the unit starts in the menu used last.

Exit all menus by pressing <ESC> repeatedly until you reach one of the main menus (main menu or quick start menu).

You can find a summary on the entire menu structure and all selectable parameters as well as options and results below.

## 9.3 Parameter Tree and Functions

Menu	1. Sub-menu	2. Sub-menu	3. Sub-menu	Description
Quick-start	Setup-Wizard	Standard Sensor		Indicates the type of sensor connected if detected automatically. Otherwise a sensor type can be defined here:  K1N, K1L, K1E, K4N K4L, K4E, N, Q, Special
		Middle line		Select values to indicate in the centre line of the display:  OFF, m/s, f/s, in/s, m3/h, m3/min, m3/s, l/h, l/min, l/s, Usgal/h, Usgal/min, Usgal/s, bbl/d, bbl/h, bbl/min, g/s, t/h, kg/h, kg/min, m3, l, Usgal, bbl, g, t, kg, W, kW, MW, J, kJ, MJ, Sig dB (signal), noise dB, SNR dB, C m/s (sound velocity), CU (Temp. In enclosure, SOS, DEN, KIN, SHC, TEMP, Tin (Temperature flow pipe), Tout (Temperature flow),
		Pipe material		Select pipe material:  stainless steel, steel, ductile cast iron, standard cast iron, copper, lead, PVC, PP, PE, ABS, glass, cement, user (enter material velocity here)
		Pipe sound velocity*		600 ... 6553.5 m/s

\* only active if "user" has been entered in the above parameter

		Outside diameter		6 ... 6500mm
		Wall thickness		0.5 ... 75 mm
		Liquid		Select the liquid being measured: water, salt water, acetone, alcohol, ammonia, carbon tetrachloride, ethanol, ethyl alcohol, diethylether, ethylene glycol, glycol/water 50%, kerosene, methanol, methyl alcohol, milk, oil, vehicle oil, freon R134a, freon R22, hydrochloric acid, sulphuric acid, toluene, vinyl chloride, User (allows to enter the sound velocity within the medium)
		Kin. viscosity*		0.01 ... 30000 mm <sup>2</sup> /s Only if "user" has been entered in liquid
		Density		100 ... 2000 kg/m <sup>3</sup> Only if "user" has been entered in liquid
		Sound velocity*		800 ... 3500 m/s Only if "user" has been entered in liquid
		Temperature		-30 ... 3000 °C
		Coating		Select the coating material: non, epoxy, rubber, PVDF, PP, glass, cement, user
		Coating thickness		1.0 ... 99.0 mm
		Sound velocity*		600 ... 6553.0 m/s (Only if "user" has been entered in coating)
		Sound paths (acoustic paths)		Select the number of acoustic paths through the medium: Auto, 1 ... 16

\* only active if "user" has been entered in the above parameter

Menu	1. Sub-menu	2. Sub-menu	3. Sub-menu	Description
	<b>Stored Setups</b>	Load		Save previously selected parameter settings here
		Store		Save and recall the current set of parameters here by entering a TAG number.
		Erase		Erase a saved set of parameters from the list here.
	<b>Start measurement</b>			Start the measurement using the current set of parameters
	<b>Oscilloscope</b>			Check amplitude and distance of signals here (for service personnel)
	<b>Total counter</b>			ON, OFF, Reset +, Reset -, Reset both (activate or deactivate the total counter here)
<b>Main menu</b>	<b>Installation</b>	Pipe	Material	Select the pipe material: Stainless steel, steel, ductile cast iron, grey cast iron, copper, lead, PVC, PP, PE, ABS, glass, cement, user (the material velocity can be entered here)  (more detailed settings to meet the demands of the measurement place can be set here)
			Diameter	6 ... 65000 mm
			Wall thickness	0.5 ... 75 mm
			Sound velocity.	600 ... 6553.5 m/s
			L Sound velocity.	600 ... 6553.5 m/s (Longitudinal velocity)
			Circumference	18.8 ... 20420.4 mm
			Roughness	0.0 ... 10 mm

Menu	1. Sub-menu	2. Sub-menu	3. Sub-menu	Description
		Medium	Liquid	Select the liquid being measured: water, salt water, acetone, alcohol, ammonia, carbon tetrachloride, ethanol, ethyl alcohol, diethyl ether, ethylene glycol, glycol/water 50%, kerosene, methanol, methyl alcohol, milk, oil, vehicle oil, freon R134a, freon R22, hydrochloric acid, sulphuric acid, toluene, vinyl chloride, User (allows to enter the sound velocity within the medium)
			Viscosity	0.001 ... 3000 mm <sup>2</sup> /s
			Density	100 ... 2000 kg/m <sup>3</sup>
			Sound velocity	800 ... 3500 m/s
			Temperature	'-30 ... 300 °C
		Coating	Material	Select the coating material: non, epoxy, rubber, PVDF, PP, glass, cement, user
			Thickness	1 ... 99 mm
			Sound velocity.	600 ... 6553.5 m/s
		Sound paths (acoustic paths)		Select the number of acoustic paths through the medium: Auto, 1 ... 16
	<b>Display</b>	Upper line		Select the value to indicate in the upper line here:  OFF, m/s, f/s, in/s, m <sup>3</sup> /h, m <sup>3</sup> /min, m <sup>3</sup> /s, l/h, l/min, l/s, Usgal/h, Usgal/min, Usgal/s, bbl/d, bbl/h, bbl/min, g/s, t/h, kg/h, kg/min, m <sup>3</sup> , l, Usgal, bbl, g, t, kg, W, kW, MW, J, kJ, MJ, Sig dB (signal), noise dB, SNR dB, C m/s (sound velocity), CU (enclosure temperature, SOS, DEN, KIN, SHC, TEMP, Tin (Temperature flow pipe), Tout (Temperature flow), back flow

Menu	1. Sub-menu	2. Sub-menu	3. Sub-menu	Description
		Center line		Select the value to indicate in the centre line here:  OFF, m/s, f/s, in/s, m <sup>3</sup> /h, m <sup>3</sup> /min, m <sup>3</sup> /s, l/h, l/min, l/s, Usgal/h, Usgal/min, Usgal/s, bbl/d, bbl/h, bbl/min, g/s, t/h, kg/h, kg/min, m <sup>3</sup> , l, Usgal, bbl, g, t, kg, W, kW, MW, J, kJ, MJ, Sig dB (signal), noise dB, SNR dB, C m/s (sound velocity), CU (enclosure temperature, SOS, DEN, KIN, SHC, TEMP, Tin (Temperature flow pipe), Tout (Temperature flow),
		Bottom line		Select the value to indicate in the bottom line here:  OFF, m/s, f/s, in/s, m <sup>3</sup> /h, m <sup>3</sup> /min, m <sup>3</sup> /s, l/h, l/min, l/s, Usgal/h, Usgal/min, Usgal/s, bbl/d, bbl/h, bbl/min, g/s, t/h, kg/h, kg/min, m <sup>3</sup> , l, Usgal, bbl, g, t, kg, W, kW, MW, J, kJ, MJ, Sig dB (signal), noise dB, SNR dB, C m/s (sound velocity), CU (enclosure temperature, SOS, DEN, KIN, SHC, TEMP, Tin Temperature flow pipe), Tout (Temperature flow),
		Damping		Reduces the display fluctuation:  1 ... 255 s
		Metric/Imperial		Use metric or imperial units
	<b>Input/ Output</b>			Indicates a list of installed input / output modules. The modules can be selected to modify the parameters.
		I OUT AKTIV Current output	Source	OFF, channel1, channel2, Mathe1, Mathe2, System, Test



Menu	1. Sub-menu	2. Sub-menu	3. Sub-menu	Description
			Unit	OFF, m/s, f/s, in/s, m <sup>3</sup> /h, m <sup>3</sup> /min, m <sup>3</sup> /s, l/h, l/min, l/s, Usgal/h, Usgal/min, Usgal/s, bbl/d, bbl/h, bbl/min, g/s, t/h, kg/h, kg/min, m <sup>3</sup> , l, Usgal, bbl, g, t, kg, W, kW, MW, J, kJ, MJ, Sig dB (signal), noise dB, SNR dB, C m/s (sound velocity), CU (enclosure temperature, SOS, DEN, KIN, SHC, TEMP, Tin (Temperature flow pipe), Tout (Temperature flow),
			Min. value	Min. process value transferred, 0/4 mA
			Max. value	Max. process value transferred, 20 mA
			Dumping	Additional damping on output, 1 ... 255 s
			measuring range	0 ... 20 mA or 4 ... 20 mA
			Error	Value in case of error: Hold (will hold value), 3.8 mA, 21.0 mA
			Hold	The output value will be held for: 1 ... 999 s
		OCT (frequency output)	Mode	Yes - Pulse output ON No - Pulse output OFF
			Pulse value	Unit per pulse, e.g. PV =[m <sup>3</sup> /h], Pulse value = 10 0.01 ... 1000
			Pulse duration	length of the pulse: 30 ... 999 ms
			Calc. Max.	Enter the calculated maximum number of impulses per second here: e.g. max. pulse rate in Hz

Menu	1. Sub-menu	2. Sub-menu	3. Sub-menu	Description
		V OUT (Current output)	Source	OFF, channel1, channel2, Mathe1, Mathe2, System, Test
			Unit	OFF, m/s, f/s, in/s, m3/h, m3/min, m3/s, l/h, l/min, l/s, Usgal/h, Usgal/min, Usgal/s, bbl/d, bbl/h, bbl/min, g/s, t/h, kg/h, kg/min, m3, l, Usgal, bbl, g, t, kg, W, kW, MW, J, kJ, MJ, Sig dB (signal), noise dB, SNR dB, C m/s (sound veloci- ty.), CU (enclosure temperature, SOS, DEN, KIN, SHC, TEMP, Tin (Temperature flow pipe), Tout (Temperature flow),
			Min. value	Min. process value transferred, 0V
			Max. value	Max. process value transferred, 10 V
			Dumping	Additional damping on output, 1 ... 255 s
		Frequency output	Source	OFF, channel1, channel2, Mathe1, Mathe2, System, Test
			Unit	OFF, m/s, f/s, in/s, m3/h, m3/min, m3/s, l/h, l/min, l/s, Usgal/h, Usgal/min, Usgal/s, bbl/d, bbl/h, bbl/min, g/s, t/h, kg/h, kg/min, m3, l, Usgal, bbl, g, t, kg, W, kW, MW, J, kJ, MJ, Sig dB (signal), noise dB, SNR dB, C m/s (sound veloci- ty.), CU (enclosure temperature, SOS, DEN, KIN, SHC, TEMP, Tin (Temperature flow pipe), Tout (Temperature flow),
			Min. value	Min. process value transferred at min. frequency
			Max. value	Max. process value transferred at max. frequency
			Dumping	Additional damping on output, 1 ... 255 s

Menu	1. Sub-menu	2. Sub-menu	3. Sub-menu	Description
		Relay	Mode	OFF - perm. OFF, ON - perm. ON, Alarm - process value Alarm, Math - calculated Alarm for limit value
			Lower Limit value	Limit value when the relay is active
			Upper Limit value	Limit value when the relay is inactive
		PT100	Source	Fix – enter a fixed temperature at 'value'  PT100 – value from PT100 sensor in °C
			Value	Here you can enter a fixed temperature, 0 ... 250 °C
			Offset	Here you can enter an Offset for the value, -100 ... 100 °C
		RS 485		specified separately
		Modbus RTU		specified separately
		HART		specified separately
	<b>System</b>	Device info	Model code	
			Serial number	
			HW Version	
			SW Version	
		Calculation	low flow limit	+/- low flow limit, 0 ... 0.025 m/s
			High flow limit	+/- high flow limit, 0 ... 30 m/s
			Corrected	Flow profile corrector: yes, no
			PV offset	Adjustment process value offset, -30 ... 30 m/s
			PV scaling	Adjustment process value scaling (as Factor), 0 ... 10000
			Zero point calibration	Adjustment menu zero point
			Zero	Make zero point calibration? yes, no

Menu	1. Sub-menu	2. Sub-menu	3. Sub-menu	Description
			Zero tracking	Make zero tracking? yes, no
			Delta-Offset	Zero point offset of the sensors read from the sensor PROM, manual entry is also possible [ns]
			Time-Offset	Here an offset can be set in the upstream time. Special sensors or cable extensions may be allo- cated
			Heat capacities	A special heat capacity of indi- vidual liquids can be specified here
		User	Measurement place	Name of measurement place: e.g. pump P3A (9 digits)
			Measuring number	Number or name of the measur- ing e.g. 1FT-3011 (9 digits)
		Test	Installation	The parameter setting can be tested here: 60 sec. increasing velocity from 0 to max. pro- grammed velocity in m/s.  Than 60 decreasing velocity like the process variable change across the full span. All parame- ter show the programmed func- tions (e.g. also all inputs and outputs)
				Test modes are also available to review: display, keyboards, memory, periphery and ultrasound
		Setup	Date	The actual or desired date can be entered here
			Time	The actual or desired time can be entered here
			Date format	You can define date format here: tt/mm/jj, mm/tt/jj or jj/mm/tt

Menu	1. Sub-menu	2. Sub-menu	3. Sub-menu	Description
			Language	Selection of language possible (e.g. English, French, Deutsch)
			Keypad	This feature turns on or off the keypad sound (keypad sound yes or no)
			Battery	You can specify if a warning should be issued when the battery level drops below a defined limit. Also how many minutes after the last use, the device should turn off (value in minutes)
			Reset the settings	Here the device can be reset to factory defaults. Date and time are not affected. (reset values: yes or no)
			Key lock	The keypad can be locked here (Key look: yes or no)
		Diagnostics		Here, the following values are chosen successive: Temperature (enclosure) [%], Data storage volume (remaining) [%,hrs.], battery (remaining) [%], battery voltage [V]
		Data logger	storage interval	The storage interval for permanent operation shall be entered here [sec].  If de mode is adjusted for cyclic measurement, the cycle time shall be entered in minutes. [Minutes].
			Selection	Select the value being stored here:  OFF, m/s, f/s, in/s, m3/h, m3/min, m3/s, l/h, l/min, l/s, Usgal/h, Usgal/min, Usgal/s, bbl/d, bbl/h, bbl/min, g/s, t/h, kg/h, kg/min, m3, l, Usgal, bbl, g, t, kg, W, kW, MW, J, kJ, MJ, Sig dB (signal), noise dB, SNR dB, C m/s (sound velocity), CU (enclosure temperature, SOS, DEN, KIN, SHC, TEMP, Tin (Temperature flow pipe), Tout (Temperature flow), back flow

Menu	1. Sub-menu	2. Sub-menu	3. Sub-menu	Description
			Memory alarm	Enter here, at which rest storage volume (in %) the device should generate an alarm.
			Memory Readout	If this menu is chosen, the device will try to transfer the stored data as a stream via serial interface. This happens without confirmation or query for receiving data.
			Clear memory	Query: yes - The data memory is cleared completely and irrevocably. No- exit the menu without changing
			Ser. Comm.	Here the serial interface can be initialized
			Mode	Non (standard data transmission), Printer (continuously every sec.), Diagnosis (special), Download (immediate transmission of all stored data), Cal. Test (production test)
			Baud rate	Chose the transfer speed here: 9600, 19200, 57600, 115200
			Parity	Set the transfer parity here (Protocol checking): none, even, odd
			Type	Selection RS232, RS485, etc. depending on installed communication cards.

## 10 Data evaluation

### 10.1 Data handling possibilities

Saved data can be downloaded from the unit or handled in several ways.  
Data can be:

- loaded directly into the NivuSoft software via USB interface
- transmitted to a Software which is able to read data streams (such as Microsoft Hyper Terminal)
- optionally transmitted to D2W from the external data logger NivuLog Easy.

## 11 Error description

Error message	Group	Description	fault recovery
USB INIT FAIL	Hardware	Internal board communication error	Turn the unit off and on again, Contact customer service
NO SERIAL NO.	Hardware	Errors occurred when reading FRAM	Contact customer service
NO VERSION NO.	Hardware	Errors occurred when reading FRAM	Contact customer service
PARA READ FAIL	Hardware	Errors occurred when reading FRAM	Contact customer service
PARA WRITE FAIL	Hardware	Errors occurring when writing FRAM	Contact customer service
VAR READ FAIL	Hardware	Errors occurred when reading FRAM	Contact customer service
VER WRITE FAIL	Hardware	Errors occurring when writing FRAM	Contact customer service
SYSTEM ERROR	Hardware		Contact customer service
VISIBILITY ERR	Hardware	Errors occurred when reading FRAM	Contact customer service
FRAM LONG WRITE ERR	Hardware	Errors occurring when writing FRAM	Contact customer service
FRAM READ ERR	Hardware	Errors occurred when reading FRAM	Contact customer service
TC ERR	Hardware	Real time error	Turn the unit off and on again , Contact customer service
EXTMEM ERR	Hardware	Data memory error	Turn the unit off and on again , Contact customer service
SPI ERR	Hardware	SPI Bus Error	Turn the unit off and on again , Contact customer service
I2C ERR	Hardware	I2C Bus Error	Turn the unit off and on again , Contact customer service
MATH ERR	Software	Internal calculation error	Contact customer service

STACK ERR	Software	Internal calculation error	Contact customer service
ADDR ERR	Software	Internal calculation error	Contact customer service
OSC ERR	Software	Internal calculation error	Contact customer service
ADC ERR	Software	Internal calculation error	Contact customer service
IO ERR	Software	Internal calculation error	Contact customer service
TIMING ERR	Software	Internal calculation error	Contact customer service
COMM INIT ERR	Hardware	Internal communication error	Turn the unit off and on again, Contact customer service
COMM START ERR	Hardware	Internal communication error	Turn the unit off and on again, Contact customer service
COMM HS0 ERR	Hardware	Internal communication error	Turn the unit off and on again, Contact customer service
COMM HS1 ERR	Hardware	Internal communication error	Turn the unit off and on again, Contact customer service
COMM READ AVE ERR	Hardware	Internal communication error	Turn the unit off and on again, Contact customer service
COMM READ RAW ERR	Hardware	Internal communication error	Turn the unit off and on again, Contact customer service
COMM READ HISTORY ERR	Hardware	Internal communication error	Turn the unit off and on again, Contact customer service
COMM CRC ERR	Hardware	Internal communication error	Turn the unit off and on again, Contact customer service
SENSOR COUPLING ERR	Application	Poor sensor coupling to pipe wall. Low SNR (signal to noise ratio)	Reapply coupling paste to sensors. Verify the measurement system installation. Reduce the number of signal paths through the medium. Find better options to install the sensors. Contact customer service.



## 12 Analog Inputs and Outputs

The PCO may be equipped with several analog inputs and outputs which can be used to either tap or feed analog signals. Equipment as well as wiring of inputs and outputs depend on the PCO equipment version.

A detailed overview on the various equipment versions and the according connections can be found in the table below.

Article No.	Slot 1	Slot 2	Slot 3	Slot 4
PCO-P0000001EAA	In 0/4 - 20 mA active			
PCO-P0000001EAP	In 0/4 - 20 mA passive			
PCO-P0000002EAA	In 0/4 - 20 mA active	In 0/4 - 20 mA active		
PCO-P0000002EAP	In 0/4 - 20 mA passive	In 0/4 - 20 mA passive		
PCO-P0001AA0000	Out 0/4 - 20 mA			
PCO-P0001AA1EAA	Out 0/4 - 20 mA	In 0/4 - 20 mA active		
PCO-P0001AA1EAP	Out 0/4 - 20 mA	In 0/4 - 20 mA passive		
PCO-P0001AA2EAA	Out 0/4 - 20 mA	In 0/4 - 20 mA active	In 0/4 - 20 mA active	
PCO-P0001AA2EAP	Out 0/4 - 20 mA	In 0/4 - 20 mA passive	In 0/4 - 20 mA passive	
PCO-P0001AV0000	Out 0 - 10 V			
PCO-P0001AV1EAA	Out 0 - 10 V	In 0/4 - 20 mA active		
PCO-P0001AV1EAP	Out 0 - 10 V	In 0/4 - 20 mA passive		
PCO-P0001AV2EAA	Out 0 - 10 V	In 0/4 - 20 mA active	In 0/4 - 20 mA active	
PCO-P0001AV2EAP	Out 0 - 10 V	In 0/4 - 20 mA passive	In 0/4 - 20 mA passive	
PCO-P0002AA0000	Out 0/4 - 20 mA	Out 0/4 - 20 mA		
PCO-P0002AA1EAA	Out 0/4 - 20 mA	Out 0/4 - 20 mA	In 0/4 - 20 mA active	
PCO-P0002AA1EAP	Out 0/4 - 20 mA	Out 0/4 - 20 mA	In 0/4 - 20 mA passive	
PCO-P0002AA2EAA	Out 0/4 - 20 mA	Out 0/4 - 20 mA	In 0/4 - 20 mA active	In 0/4 - 20 mA active
PCO-P0002AA2EAP	Out 0/4 - 20 mA	Out 0/4 - 20 mA	In 0/4 - 20 mA passive	In 0/4 - 20 mA passive
PCO-P0002AV0000	Out 0 - 10 V	Out 0 - 10 V		
PCO-P0002AV1EAA	Out 0 - 10 V	Out 0 - 10 V	In 0/4 - 20 mA active	
PCO-P0002AV1EAP	Out 0 - 10 V	Out 0 - 10 V	In 0/4 - 20 mA passive	
PCO-P0002AV2EAA	Out 0 - 10 V	Out 0 - 10 V	In 0/4 - 20 mA active	In 0/4 - 20 mA active
PCO-P0002AV2EAP	Out 0 - 10 V	Out 0 - 10 V	In 0/4 - 20 mA passive	In 0/4 - 20 mA passive

Fig. 12-1 Equipment versions analog inputs and outputs

Slot	Terminal clamp wiring Connector-Box PCO0ZVS1	Wire assignment Multi connection cable PCO0ZVMULTI	Out 0/4 - 20 mA	Out 0 - 10 V	In 0/4 - 20 mA active	In 0/4 - 20 mA passive
Slot 1	1	blue	GND	GND	-	GND in
	2	grey	-	-	-	0 V out
	3	red	0/4 - 20 mA	+10 V	20 mA in	-
	4	brown	-	-	+30 V out	-
Slot 2	5	yellow	GND	GND	-	GND in
	6	white	-	-	-	0 V out
	7	green	0/4 - 20 mA	+10 V	20 mA in	-
	8	pink	-	-	+30 V out	-
Slot 3	9	-	GND	GND	-	GND in
	10	-	-	-	-	0 V out
	11	-	0/4 - 20 mA	+10 V	20 mA in	-
	12	-	-	-	+30 V out	-
Slot 4	13	-	GND	GND	-	GND in
	14	-	-	-	-	0 V out
	15	-	0/4 - 20 mA	+10 V	20 mA in	-
	16	-	-	-	+30 V out	-

Fig. 12-2 Connection wiring analog inputs and outputs

**Example:**

Version: PCO-P0001AA1EAA

Article No.	Slot 1	Slot 2	Slot 3	Slot 4
PCO-P0000001EAA	In 0/4 - 20 mA active			
PCO-P0000001EAP	In 0/4 - 20 mA passive			
PCO-P0000002EAA	In 0/4 - 20 mA active	In 0/4 - 20 mA active		
PCO-P0000002EAP	In 0/4 - 20 mA passive	In 0/4 - 20 mA passive		
PCO-P0001AA0000	Out 0/4 - 20 mA			
PCO-P0001AA1EAA	Out 0/4 - 20 mA	In 0/4 - 20 mA active		
PCO-P0001AA1EAP	Out 0/4 - 20 mA	In 0/4 - 20 mA passive		

Slot	Terminal clamp wiring Connector-Box PCO0ZVS1	Wire assignment Multi connection cable PCO0ZVMULTI	Out 0/4 - 20 mA	Out 0 - 10 V	In 0/4 - 20 mA active	In 0/4 - 20 mA passive
Slot 1	1	blue	GND	GND	-	GND in
	2	grey	-	-	-	0 V out
	3	red	0/4 - 20 mA	+10 V	20 mA in	-
	4	brown	-	-	+30 V out	-
Slot 2	5	yellow	GND	GND	-	GND in
	6	white	-	-	-	0 V out
	7	green	0/4 - 20 mA	+10 V	20 mA in	-
	8	pink	-	-	+30 V out	-

Slot 1 = Out 0/4 - 20 mA → Terminal clamps 1 and 3 or blue and red

Slot 2 = In 0/4 - 20 mA aktiv → Terminal clamps 7 and 8 or green and pink

### 12.1 Analog output Current 0/4 – 20 mA

The analog output (current) works in a range of 4 - 20 mA or 0 - 20 mA.

The function can be set in the menu used to set the analog output parameters.

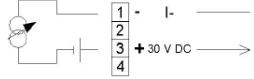
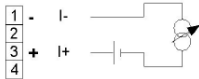
Wiring	<p>Active output (optional)</p>  <p>Passive output (optional)</p> 
Characteristic	<p>Range: 0/4-20 mA active or 4-20 mA passive option</p> <p>Galvanic separated</p> <p>Passive: U= 9 – 30 V; R= 50 Ohm (norm)</p> <p>Resolution= 16 bit</p> <p>Measurement uncertainty: 0.1 % of measurement value</p> <p>Active: R&lt; 500 Ohm, U= 30 V</p> <p>Resolution = 16 bit</p> <p>Measurement uncertainty: 0.1 % of measurement value</p>

### 12.2 Analog output Voltage 0 – 10 V

The function can be set in the menu used to set the analog output parameters.

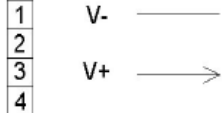
Wiring	<p>Voltage output (optional)</p> 
Characteristic	<p>Range: 0-10 V</p> <p>Galvanic separated</p> <p>R = 1000 Ohm</p> <p>Resolution = 16 bit</p> <p>Measurement uncertainty: 0.1 % of measurement value</p>

### 12.3 Analog inputs Power 0/4 – 20 mA

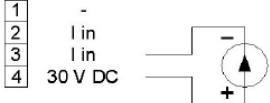
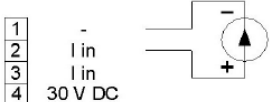
Wiring	<p>Analog input (optional)</p>  <p>Analog input (optional)</p> 
Characteristic	<p>Active or passive wiring</p> <p>Measurement range for active = 0-20 mA at 30 V</p> <p>Measurement range for active = 4-20 mA</p> <p>Measurement uncertainty: 0.1 % of measurement value</p>

## 13 Maintenance and Cleaning

**WARNING**



**Germ contamination**

*Please note that due to the operation in the waste water field the measurement system and cables may be loaded with dangerous disease germs. Respective precautionary measures must be taken to avoid damage to one's health.*

The device Type PCO is designed to be virtually maintenance-free and free of material wear and does not need to be calibrated.

If required clean the transmitter enclosure if with a dry, lint-free cloth. For heavy pollution NIVUS recommends the use of surface-active agents.

The use of abrasive cleansing agents is not allowed.



*If you wish to clean the enclosure surface with a damp cloth please disconnect the unit from mains before.*

**WARNING**



**Damage through hard objects**

*No hard objects such as wire brushes, rods, scrapers or similar shall be used to clean the sensors.*

*Never use scrubbing, scouring cleansing agents or other tools / media which might have abrasive effects or organic solvents to clean sensor cables and sensors.*

*If the sensors have been removed from the pipe for cleaning measures, the measurement system needs to be recalibrated after cleaning.*

*Recalibration in this case can be avoided by using the pipe mounting system (ZUBOCORAIL).*

### 13.1 Accessories (optional)

Battery charger ZUB0 PCOLG	Input: 100 to 240 V 50 to 60 Hz 0,5 A Output: 9 VDC, 2 A
Clamping system ZUB0 SPSYS08	consisting of tensioning belt, width 8 mm and 2 turnbuckles for fastening of 2 sensors; incl. coupling paste
Rail system ZUB0 CORAIL	consisting of tensioning belt, 2 turnbuckles and split, movable sensor receptacles
Connection cable PCO0 ZVMULTI	Multi-Connection cable for analog input and output, length 10 m
Connector-Box PCO0 ZVS1	for connection to multifunctional socket of the measurement transmitter, incl. 1 m cable and plug,

## 14 Emergency

In case of emergency

- Switch the device off by pressing and holding the >ESC< button.

## 15 Dismantling/Disposal

The device shall be disposed according to the local regulations for electronic products.



---

*Please ensure to dispose of used batteries according to environmental regulations.*

*Used rechargeable batteries can either be returned to the manufacturer or taken to respective collection points.*

---

## 16 Table of Pictures

Fig. 3-1	PCO nameplate.....	8
Fig. 3-2	Nameplate flow velocity sensor, type NICO .....	8
Fig. 4-1	Overview PCO and sensors.....	10
Fig. 4-2	Overview Clamp-on sensor.....	10
Fig. 5-1	Assembly of clamp on sensors incl. strap .....	14
Fig. 5-2	One-path transit time measurement principle .....	15
Fig. 5-3	Type keys for PCO transmitters .....	17
Fig. 5-4	Type keys for clamp on sensors NIM0K1P .....	17
Fig. 5-5	Type keys for clamp on sensors NIM0K1L .....	17
Fig. 7-1	PCO Enclosure.....	21
Fig. 7-2	PCO Enclosure and connection sockets.....	22
Fig. 7-3	Sensor pair (sensor A and B).....	23
Fig. 7-4	Clamp band for clamp on sensors .....	23
Fig. 7-5	1 path measuring, path arrangement: V-monitoring .....	24
Fig. 7-6	1 path measuring, path arrangement: diagonal .....	24
Fig. 7-7	Recommended installation angles .....	25
Fig. 7-8	Sensor position behind curves or elbows .....	26
Fig. 7-9	Sensor position after change of profile (side view) .....	26
Fig. 7-10	Comparison of installation places .....	27
Fig. 7-11	Horizontal pipe with inverted siphon .....	27
Fig. 7-12	Using shut-off valves and control fittings .....	28
Fig. 7-13	Connection Battery charger with PCO .....	30
Fig. 8-1	Operator panel .....	32
Fig. 8-2	Display.....	33
Fig. 12-1	Equipment versions analog inputs and outputs .....	49
Fig. 12-2	Connection wiring analog inputs and outputs .....	50

## 17 Index

<b>A</b>			<b>N</b>		
Accessories	52		Names	3	
<b>B</b>			<b>O</b>		
Basic menus	34		Operating permits	13	
<b>C</b>			Operation	34	
Cable			Operator Panel	32	
Bending Radius	22		<b>P</b>		
Calming Sections	26		Parameter Setting	35	
Change of Profile	26		<b>Q</b>		
Copyright	3		Quick Start	35	
<b>D</b>			<b>R</b>		
Danger by electric voltage	7		Receipt	18	
Danger Notes	7		Reinigung	52	
Delivery	18		Return	19	
Device ID	8		<b>S</b>		
Device Versions	17		Sensor		
Display	33		Connection	28	
Documentation	18		Installation position	25	
<b>E</b>			Recommended range	27	
Error Description	47		Specifications		
<b>F</b>			Transmitter	12	
Flow Calculation	16		Storing	18	
Flow Velocity Detection	15		<b>T</b>		
Functional Principle	14		Translation	3	
<b>G</b>			Transmitter		
Graphic Display	33		Installation	20	
<b>I</b>			Transport	19	
Initial Start-Up	31		Type Keys	17	
Installation	20		<b>U</b>		
<b>M</b>			Use in accordance with the requirements	11	
Maintenance	52				

